

Kaminöfen

Flamingo[®] DELUXE

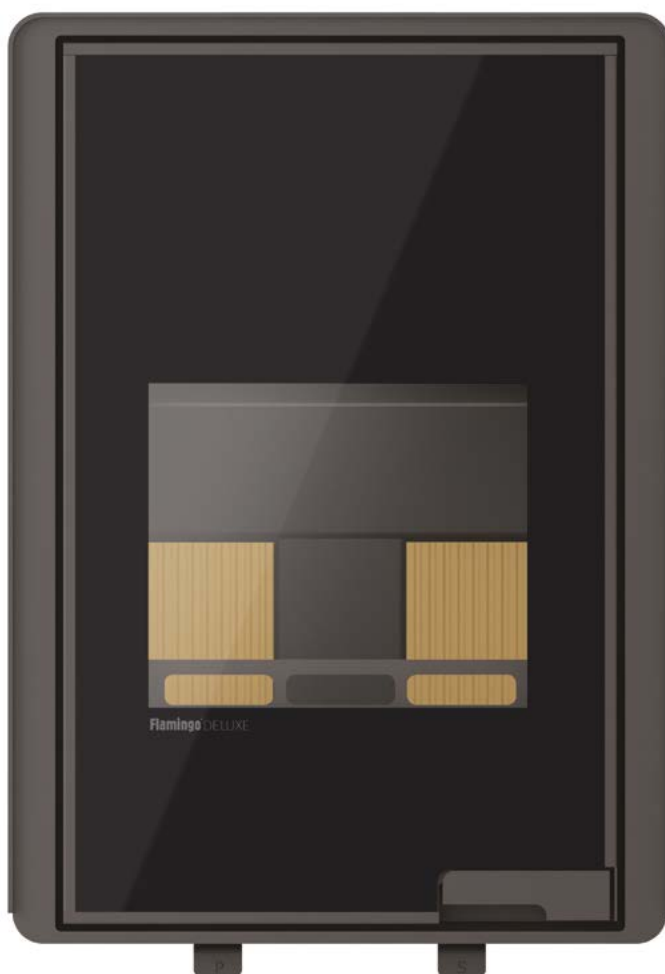

**DESIGN THAT
CREATES WARMTH**

www.hsflamingo.com



Flamingo[®] DELUXE

Technischer Querschnitt des Ofens

Flamingo DELUXE ®



1 Design, das Sie wollen

2 Bearbeitung des Produktes in TOP-Qualität

3 Feuer, das Sie sehen müssen

4 Das Glass muss rein sein... und das ist es auch

5 Fließende Regulierung der Intensität des Feuers

olive

braun - samten

grau



rot

creme

schwarz



Genauere Verbrennungsregelung

Um die genaueste Verbrennungsregulierung zu erreichen, haben Sie zwei Regler der Primär- und Sekundär/Tertiärluft zur Verfügung.



Externe Luftzufuhr

Deutlich verbessert den Verbrennungsprozess in Neubauten und „abgedichteten“ Räumen.

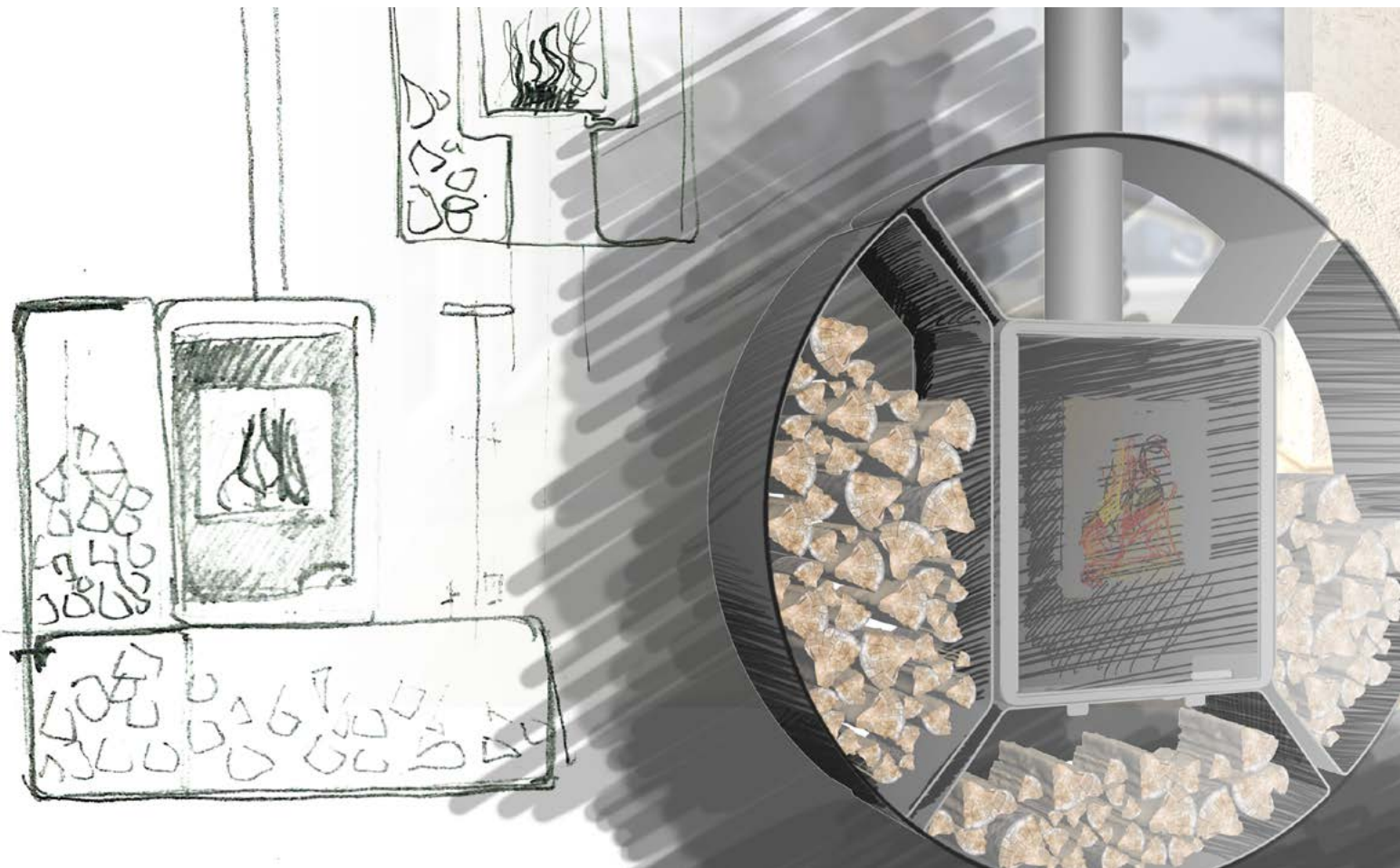

Kaminofen

malia



Einfach Montage an der Wand

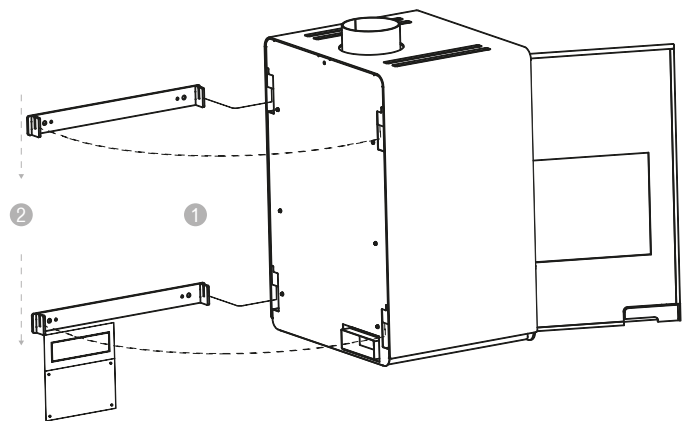

- + Top-Qualität Verarbeitung
- + Zeitlos Design
- + Primär-, Sekundär- und Tertiärluft
- + Vermiculite Verkleidung
- + Anschluss für externe Luftzufuhr
- + Aschebehälter

Technische Daten

Nennleistung kW	9
Leistungsbereich kW	3 - 11
Wirkungsgrad %	80.17
Brennstoffverbrauch kg/h	2.9
Mindestkaminzug Pa	12 - 14
Rauchrohr-Durchmesser mm	150
Länge der Holzscheite cm	35
Gewicht kg	151
CO-emission (BEI 13% O2) %	0.077
Mittlere abgastemperatur °C	287
Beheizbares Raumvolumen m ³	60 - 220
Herstellergarantie	5 Jahre

schwarz

hergestellt von HS Flamingo s.r.o.

www.hsflamingo.com

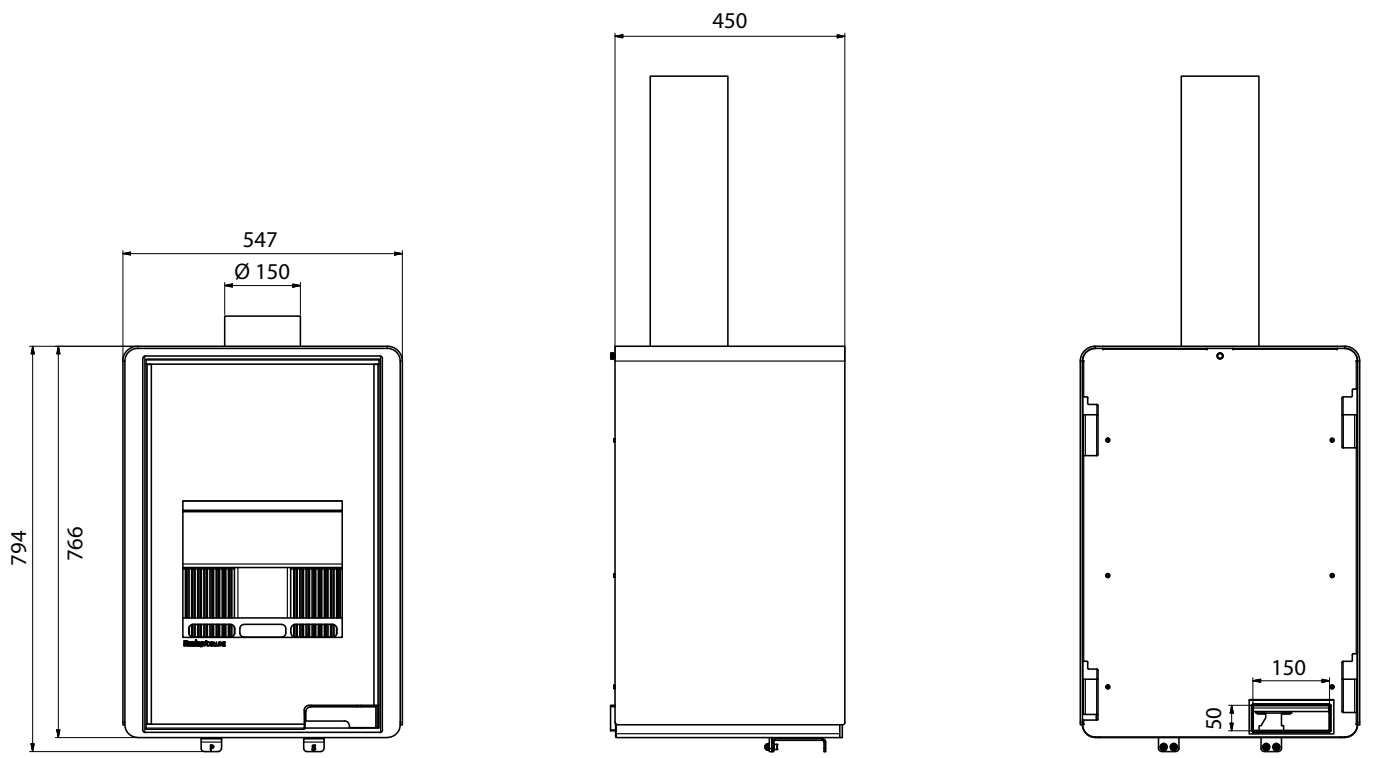

Kaminofen

pentai



Technische Daten

Nennleistung kW	9
Leistungsbereich kW	3 - 11
Wirkungsgrad %	80.17
Brennstoffverbrauch kg/h	2.9
Mindestkaminzug Pa	12 - 14
Rauchrohr-Durchmesser mm	150
Länge der Holzscheite cm	35
Gewicht kg	175
CO-emission (BEI 13% O2) %	0.077
Mittlere abgastemperatur °C	287
Beheizbares Raumvolumen m³	60 - 220
Herstellergarantie	5 Jahre

- + Top-Qualität Verarbeitung
- + Zeitlos Design
- + Primär-, Sekundär- und Tertiärluft
- + Vermiculite Verkleidung
- + Anschluss für externe Luftzufuhr
- + Aschebehälter

rot
braun - samten
creme
olive
grau



schwarz

hergestellt von HS Flamingo s.r.o.

www.hsflamingo.com

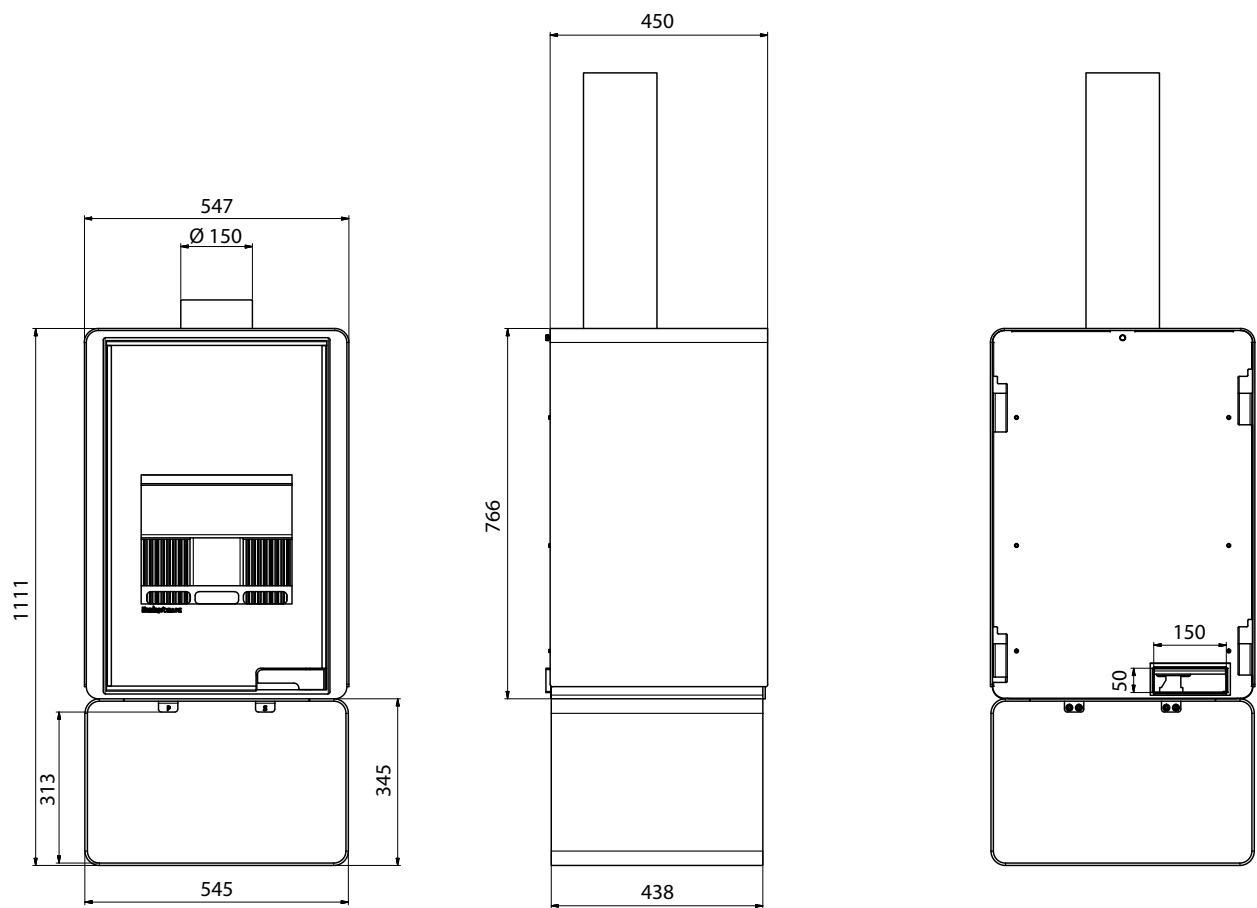





Kaminofen

kampa

rechts



Technische Daten

Nennleistung kW	9
Leistungsbereich kW	3 - 11
Wirkungsgrad %	80.17
Brennstoffverbrauch kg/h	2.9
Mindestkaminzug Pa	12 - 14
Rauchrohr-Durchmesser mm	150
Länge der Holzscheite cm	35
Gewicht kg	237
CO-emission (BEI 13% O2) %	0.077
Mittlere abgastemperatur °C	287
Beheizbares Raumvolumen m³	60 - 220
Herstellergarantie	5 Jahre

- + Top-Qualität Verarbeitung
- + Zeitlos Design
- + Primär-, Sekundär- und Tertiärluft
- + Vermiculite Verkleidung
- + Anschluss für externe Luftzufuhr
- + Aschebehälter

schwarz
rot
creme
olive
grau



braun - samten

hergestellt von HS Flamingo s.r.o.

www.hsflamingo.com

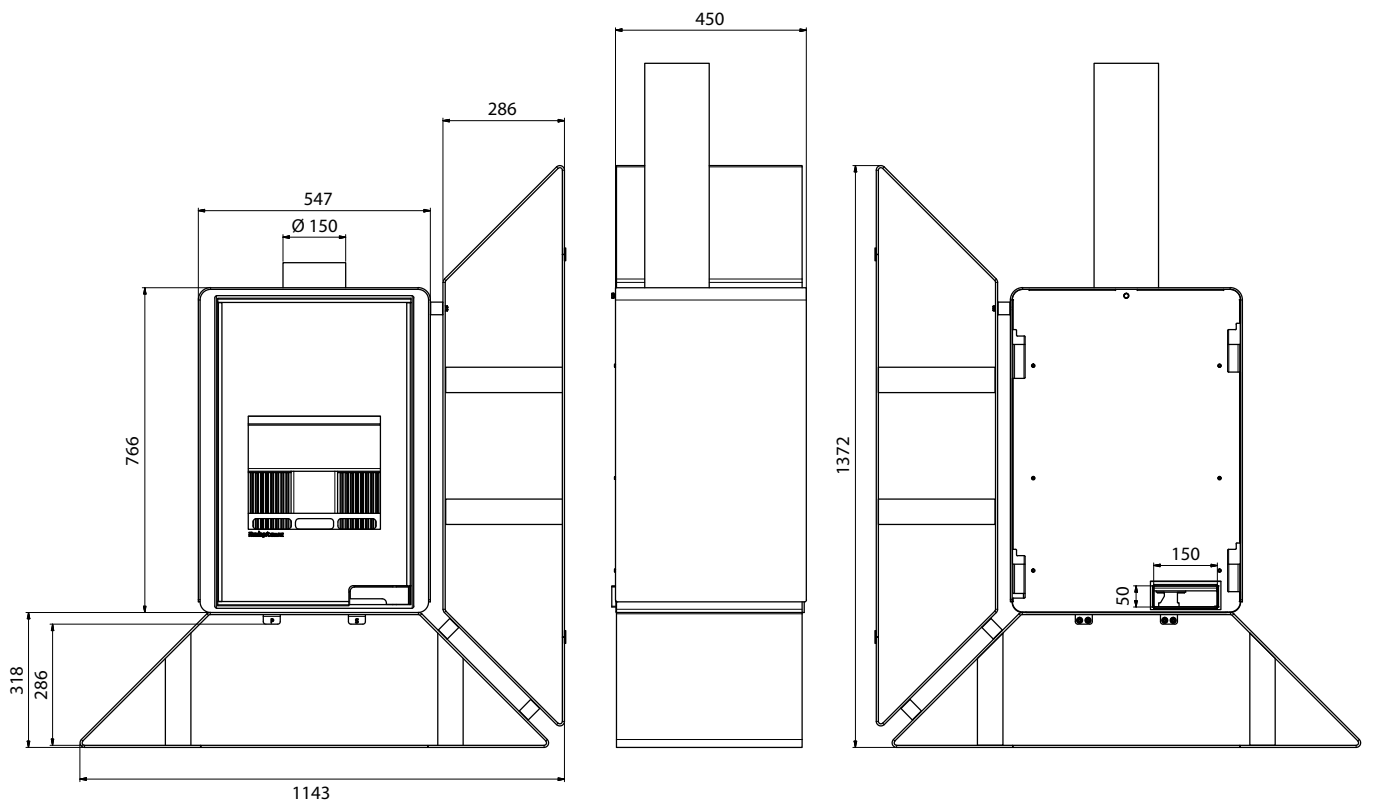





Kaminofen

kampa links



Technische Daten

Nennleistung kW	9
Leistungsbereich kW	3 - 11
Wirkungsgrad %	80.17
Brennstoffverbrauch kg/h	2.9
Mindestkaminzug Pa	12 - 14
Rauchrohr-Durchmesser mm	150
Länge der Holzscheite cm	35
Gewicht kg	237
CO-emission (BEI 13% O ₂) %	0.077
Mittlere abgastemperatur °C	287
Beheizbares Raumvolumen m ³	60 - 220
Herstellergarantie	5 Jahre

- + Top-Qualität Verarbeitung
- + Zeitlos Design
- + Primär-, Sekundär- und Tertiärluft
- + Vermiculite Verkleidung
- + Anschluss für externe Luftzufuhr
- + Aschebehälter

schwarz
rot
braun - samten
olive
grau



creme

hergestellt von HS Flamingo s.r.o.

www.hsflamingo.com

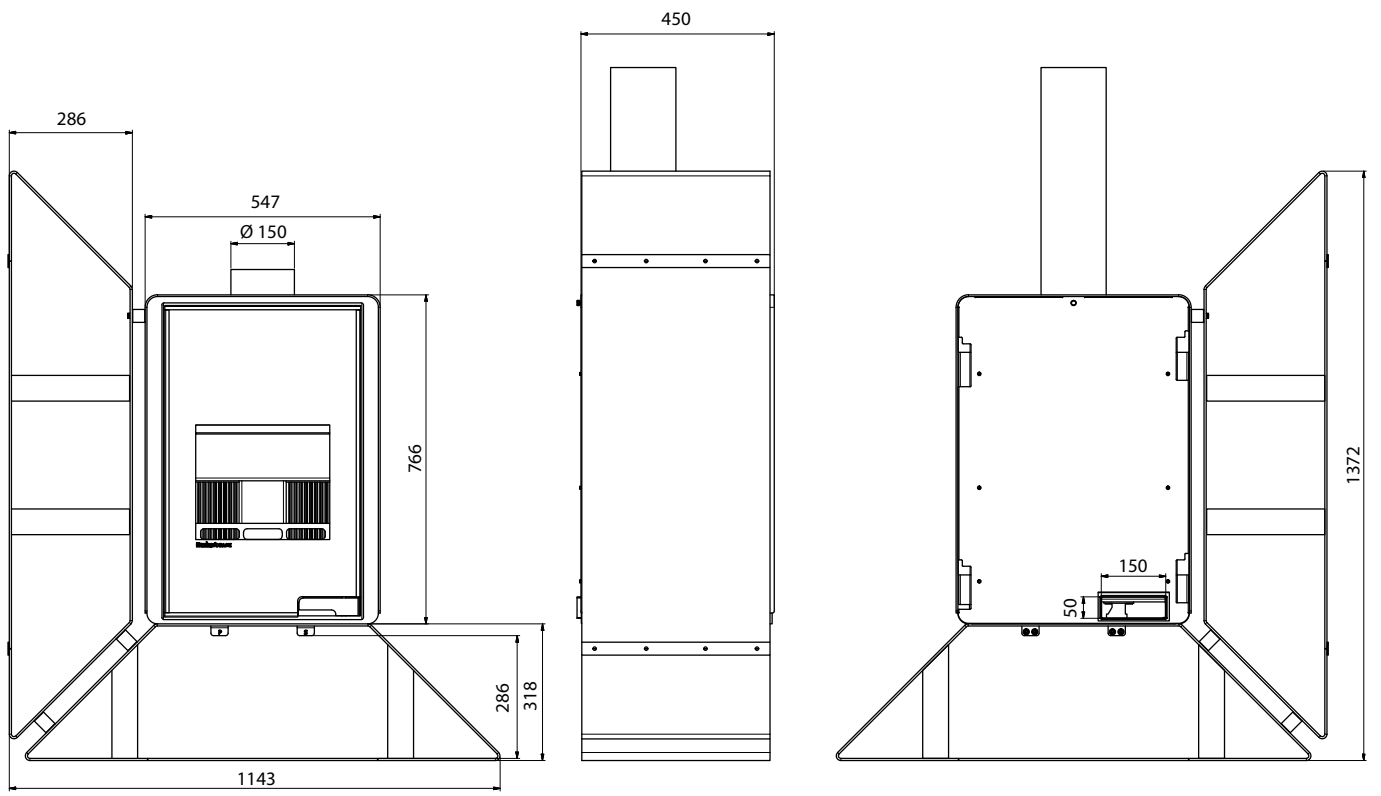





Kaminofen

senai



Technische Daten

Nennleistung kW	9
Leistungsbereich kW	3 - 11
Wirkungsgrad %	80.17
Brennstoffverbrauch kg/h	2.9
Mindestkaminzug Pa	12 - 14
Rauchrohr-Durchmesser mm	150
Länge der Holzscheite cm	35
Gewicht kg	189
CO-emission (BEI 13% O2) %	0.077
Mittlere abgastemperatur °C	287
Beheizbares Raumvolumen m³	60 - 220
Herstellergarantie	5 jahre

- + Top-Qualität Verarbeitung
- + Zeitlos Design
- + Primär-, Sekundär- und Tertiärluft
- + Vermiculite Verkleidung
- + Anschluss für externe Luftzufuhr
- + Aschebehälter

schwarz
braun - samten
creme
olive
grau



rot

hergestellt von HS Flamingo s.r.o.

www.hsflamingo.com

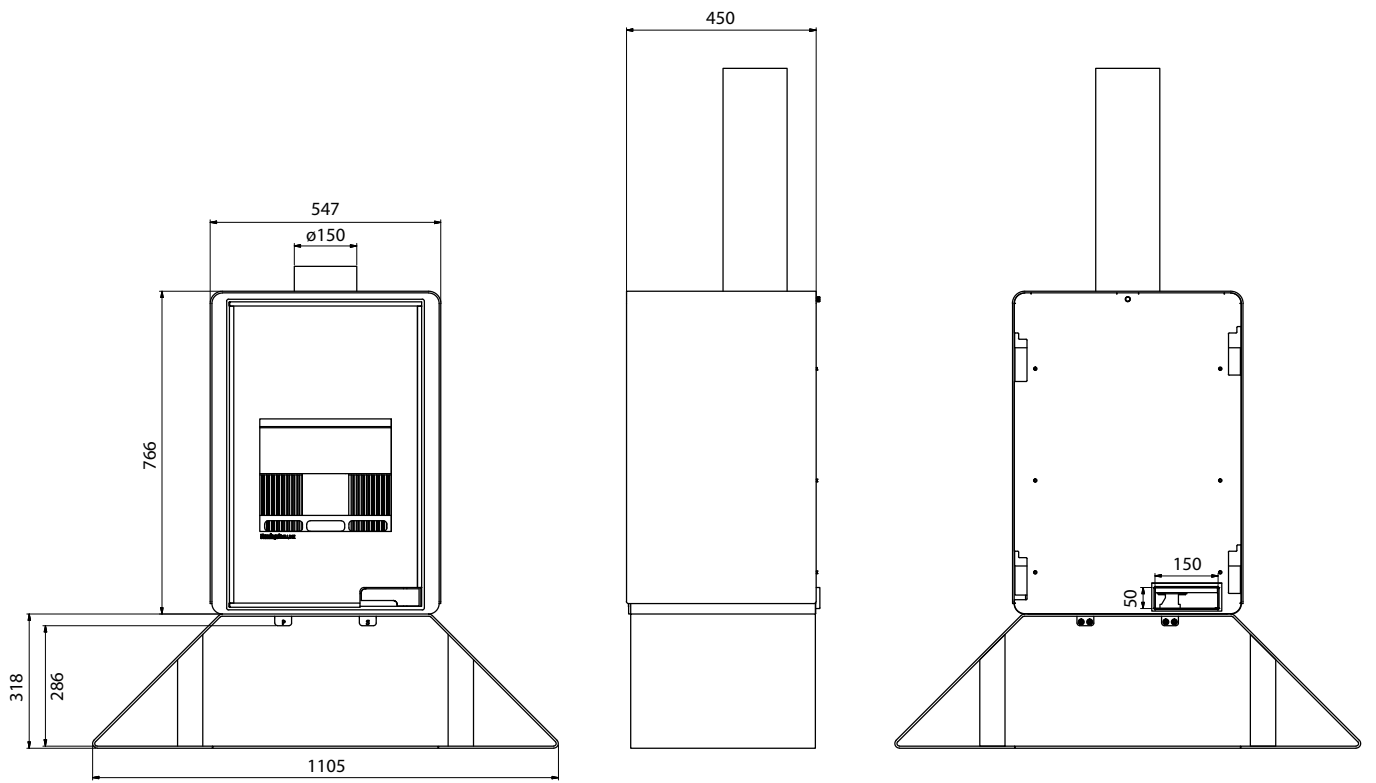





Kaminofen

singa



Technische Daten

Nennleistung kW	9
Leistungsbereich kW	3 - 11
Wirkungsgrad %	80.17
Brennstoffverbrauch kg/h	2.9
Mindestkaminzug Pa	12 - 14
Rauchrohr-Durchmesser mm	150
Länge der Holzscheite cm	35
Gewicht kg	196
CO-emission (BEI 13% O ₂) %	0.077
Mittlere abgastemperatur °C	287
Beheizbares Raumvolumen m ³	60 - 220
Herstellergarantie	5 Jahre

- + Top-Qualität Verarbeitung
- + Zeitlos Design
- + Primär-, Sekundär- und Tertiärluft
- + Vermiculite Verkleidung
- + Anschluss für externe Luftzufuhr
- + Aschebehälter

schwarz
rot
braun - samten
creme
grau



olive

hergestellt von HS Flamingo s.r.o.

www.hsflamingo.com

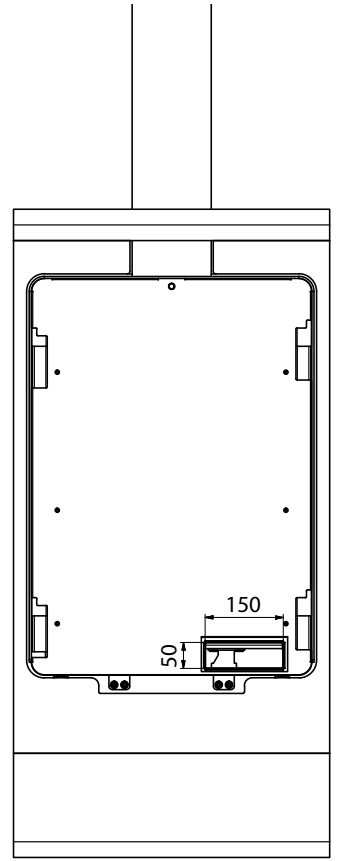
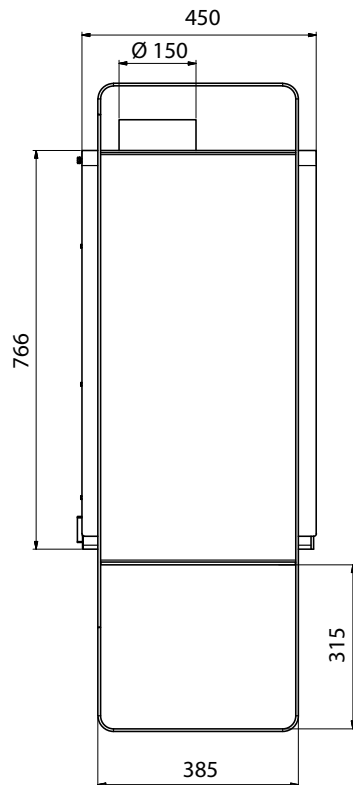
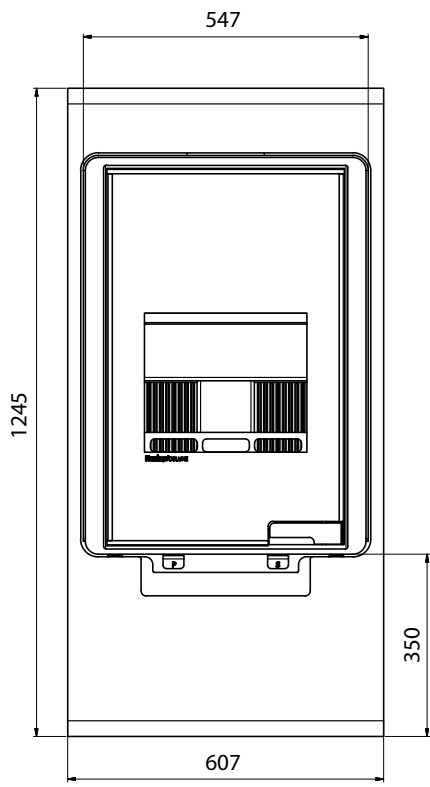





Kaminofen

island



Technische Daten

Nennleistung kW	9
Leistungsbereich kW	3 - 11
Wirkungsgrad %	80.17
Brennstoffverbrauch kg/h	2.9
Mindestkaminzug Pa	12 - 14
Rauchrohr-Durchmesser mm	150
Länge der Holzscheite cm	35
Gewicht kg	180
CO-emission (BEI 13% O2) %	0.077
Mittlere abgastemperatur °C	287
Beheizbares Raumvolumen m³	60 - 220
Herstellergarantie	5 Jahre

- + Top-Qualität Verarbeitung
- + Zeitlos Design
- + Primär-, Sekundär- und Tertiärluft
- + Vermiculite Verkleidung
- + Anschluss für externe Luftzufuhr
- + Aschebehälter

schwarz
rot
braun - samten
creme
olive



grau

hergestellt von HS Flamingo s.r.o.

www.hsflamingo.com

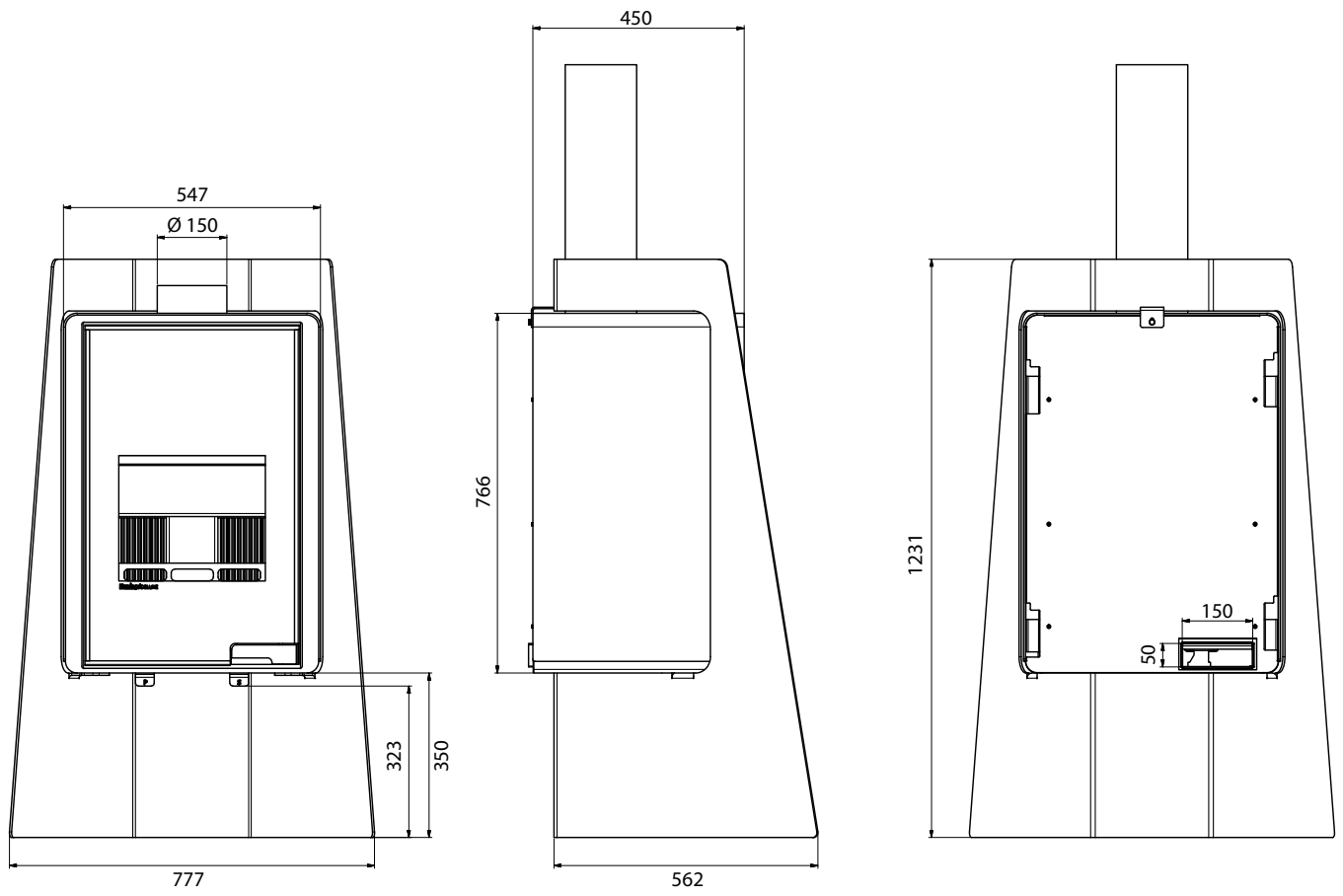



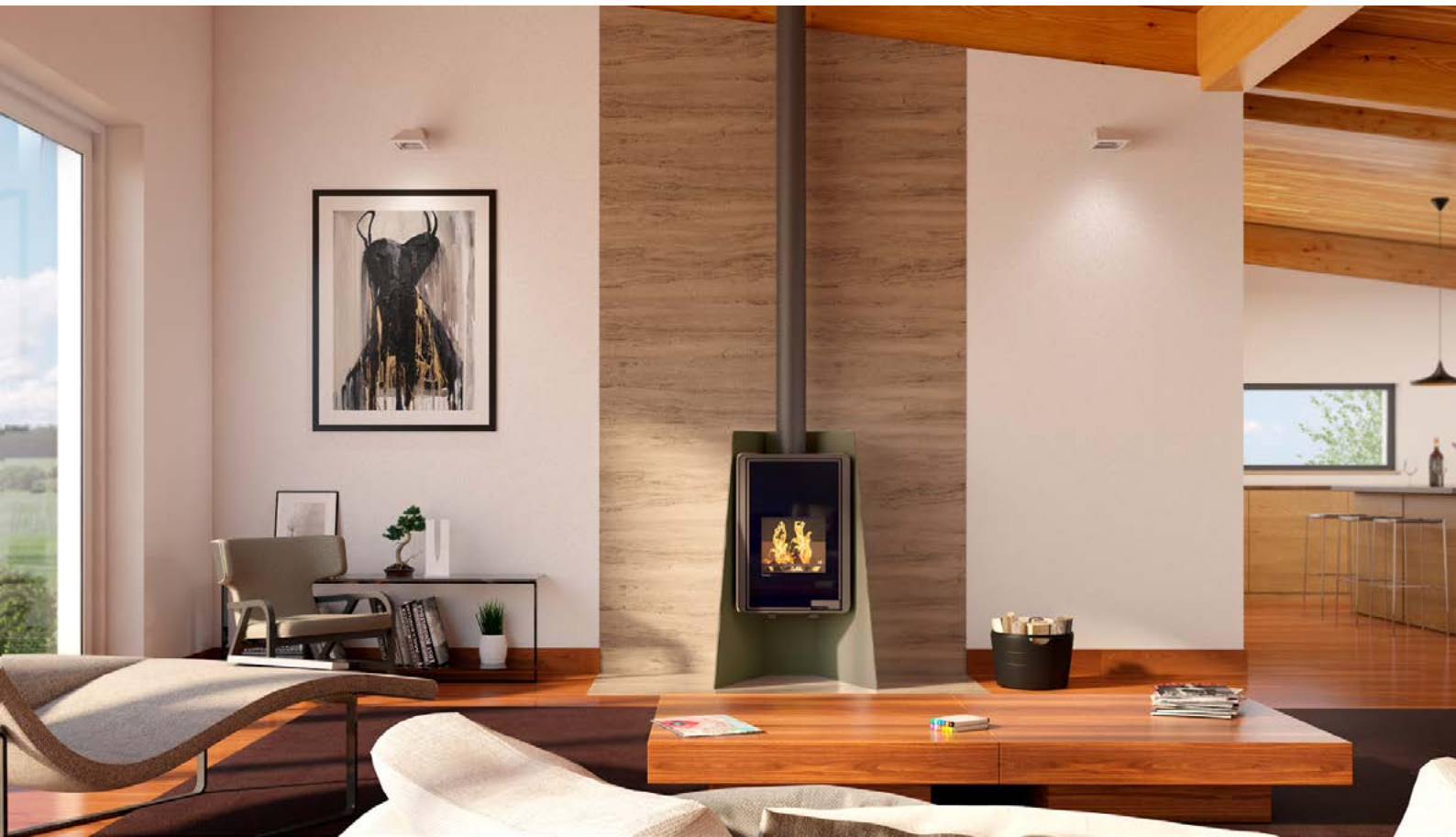

Kaminofen

pulau



Technische Daten

Nennleistung kW	9
Leistungsbereich kW	3 - 11
Wirkungsgrad %	80.17
Brennstoffverbrauch kg/h	2.9
Mindestkaminzug Pa	12 - 14
Rauchrohr-Durchmesser mm	150
Länge der Holzscheite cm	35
Gewicht kg	170
CO-emission (BEI 13% O2) %	0.077
Mittlere abgastemperatur °C	287
Beheizbares Raumvolumen m ³	60 - 220
Herstellergarantie	5 Jahre

- + Top-Qualität Verarbeitung
- + Zeitlos Design
- + Primär-, Sekundär- und Tertiärluft
- + Vermiculite Verkleidung
- + Anschluss für externe Luftzufuhr
- + Aschebehälter

schwarz
braun - samten
creme
olive
grau



rot

hergestellt von HS Flamingo s.r.o.

www.hsflamingo.com

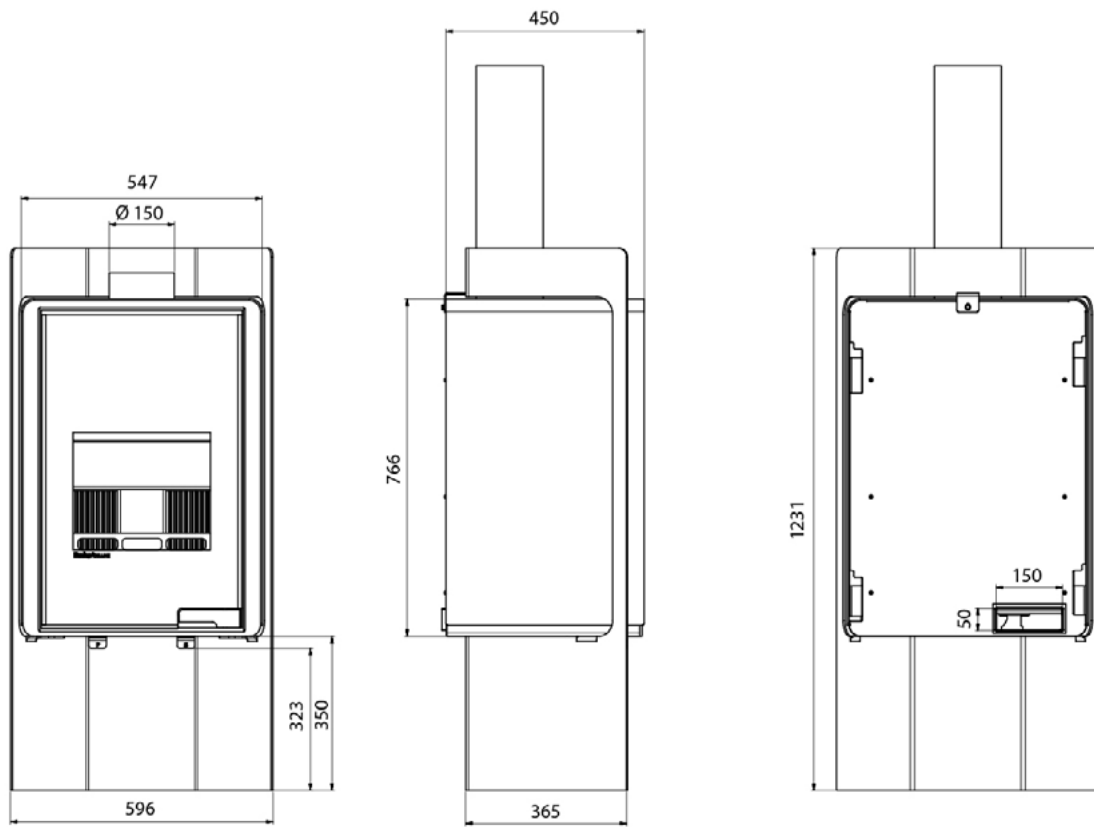





Kaminholzregal

FD - 01



eigenschaften

- + 5 mm Stahlblech
- + Hitzebeständige Zweikomponenten Farbe
- + für die Wandmontag
- + 5 Jahre Garantie

schwarz
braun - samten
creme
olive
grau



rot

hergestellt von HS Flamingo s.r.o.

www.hsflamingo.com

Kaminholzregal

FD - 02



eigenschaften

- + 5 mm Stahlblech
- + Hitzebeständige Zweikomponenten Farbe
- + für die Wandmontag
- + 5 Jahre Garantie

rot
braun - samten
creme
olive
grau



schwarz

hergestellt von HS Flamingo s.r.o.

www.hsflamingo.com

Kaminholzregal

FD - 03



eigenschaften

- + 5 mm Stahlblech
- + Hitzebeständige Zweikomponenten Farbe
- + für die Wandmontag
- + 5 Jahre Garantie

schwarz
rot
braun - samten
creme
grau



olive

hergestellt von HS Flamingo s.r.o.

www.hsflamingo.com

Kaminholzregal

FD - 04



eigenschaften

- + 5 mm Stahlblech
- + Hitzebeständige Zweikomponenten Farbe
- + für die Wandmontag
- + 5 Jahre Garantie

schwarz
rot
creme
olive
grau



braun - samten

hergestellt von HS Flamingo s.r.o.

www.hsflamingo.com

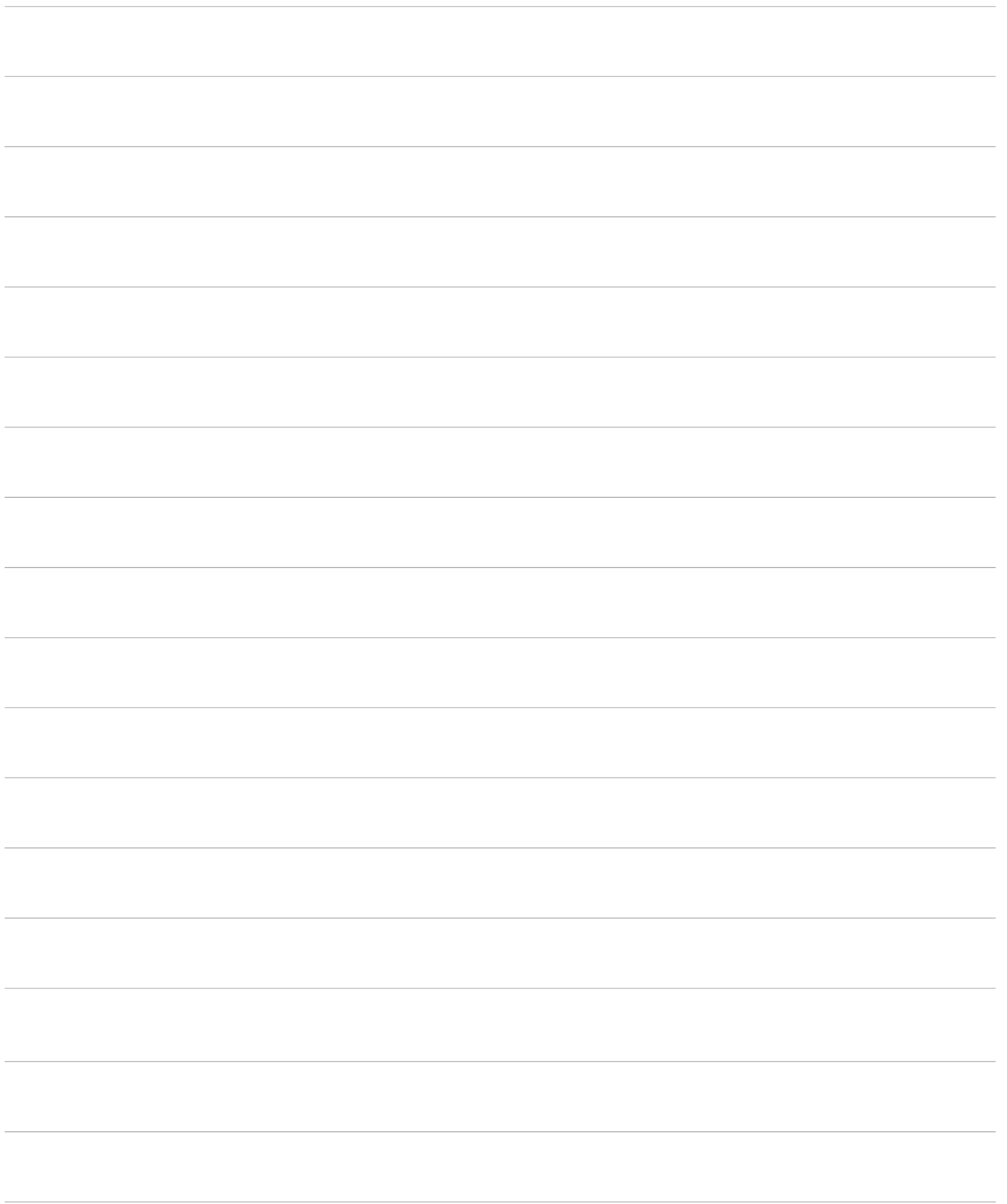

Das gesamte HS Flamingo - Angebot finden Sie auch unter
www.hsflamingo.com

Vertrieb:



HS Flamingo s.r.o.
třída Osvobození 65, CZ - 550 01
Broumov, Tschechische Republik

tel.: +420 491 422 647, fax: +420 491 521 140
e-mail: export@hsflamingo.cz

www.hsflamingo.com

Copyright © 2019 HS Flamingo s.r.o
072019